

TYG12-200 12V200Ah

Specifications

Nominal Voltage		12V
Rated capacity (20 hour rate)		200Ah
Dimensions	Length	522±2mm(20.55inch)
	Width	238±2mm(9.37inch)
	Height	218±2mm(8.58inch)
	Total Height	222±2mm(8.74inch)
Approx. Weight		54kg(118.8lbs)±3%



Outer dimensions (mm)

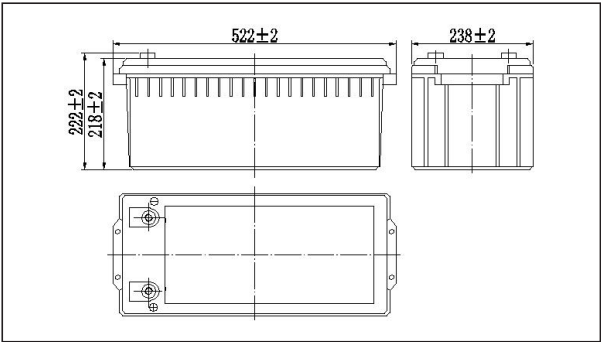

Terminal Type (mm)

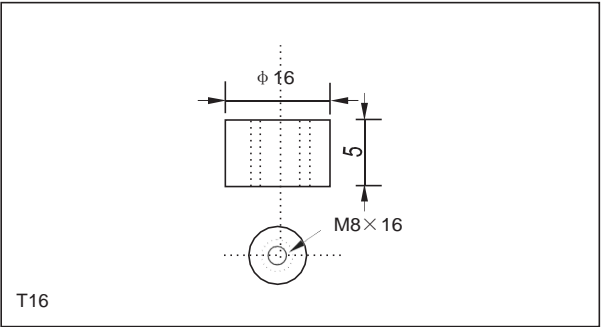

Characteristics

Capacity (25°C)	20HR(10.8V)	200Ah
	10HR(10.8V)	186Ah
	1HR(10.5V)	110Ah
Terminal type		T16
Internal resistance (Fully charged, 25°C)		Approx. 3.3m Ω
Capacity affected by temperature (10HR)	40°C	102%
	25°C	100%
	0°C	85%
	-15°C	65%
Self-discharge (25°C)	3 months	Remaining Capacity: 91%
	6 months	Remaining Capacity: 82%
	12 month	Remaining Capacity: 65%
Nominal operating temperature		25°C ±3°C(77°F ±5°F)
Operating temperature range	Discharge	-15°C~50°C(5°F~122°F)
	Charge	-10°C~50°C(14°F~122°F)
	Storage	-20°C~50°C(-4°F~122°F)
Float charging voltage(25°C)		13.50 to 13.80V Temperature compensation: -18mV/°C
Cyclic charging voltage(25°C)		14.40 to 14.70V Temperature compensation: -30mV/°C
Maximum charging current		40A
Maximum discharge current		1325A(5 sec.)
Designed floating life(20°C)		12years

Construction

Component	Positive plate	Negative plate	Container	Cover	Separator	Electrolyte	Safety valve	Terminal
Raw material	Lead dioxide	Lead	ABS	ABS	AGM	Gel	Rubber	Copper

Constant Current Discharge Characteristics Unit:A(25°C, 77°F)

F.V/Time	15m i n	30min	60min	2h	3h	4h	5h	6h	8h	10h	20h
9.60V	302	183	113	69.0	49.1	38.5	32.8	28.9	23.1	19.3	10.2
9.90V	395	180	111	68.5	48.8	38.3	32.6	28.7	22.9	19.2	10.2
10.2V	284	174	109	68.0	48.5	38.0	32.3	28.5	22.8	19.2	10.1
10.5V	275	170	106	66.9	48.1	37.8	32.1	28.3	22.7	19.0	10.1
10.8V	260	163	102	65.2	47.2	36.6	31.2	27.5	22.0	18.9	10.0

Constant Power Discharge Characteristics Unit:W(25°C, 77°F)

F.V/Time	15min	30min	60min	2h	3h	4h	5h	6h	8h	10h	20h
9.60V	3317	2055	1291	799	578	453	387	342	275	229	122
9.90V	3237	2013	1271	794	574	450	385	340	273	229	122
10.2V	3118	1952	1239	787	570	447	382	337	271	228	122
10.5V	3011	1905	1201	775	566	444	379	335	269	227	121
10.8V	2853	1835	1162	755	555	430	368	325	261	226	120

Note: The above characteristics data can be obtained within three charge or discharge cycles.

TYG12-200Ah 12V200Ah

Discharge characteristics(25°C)

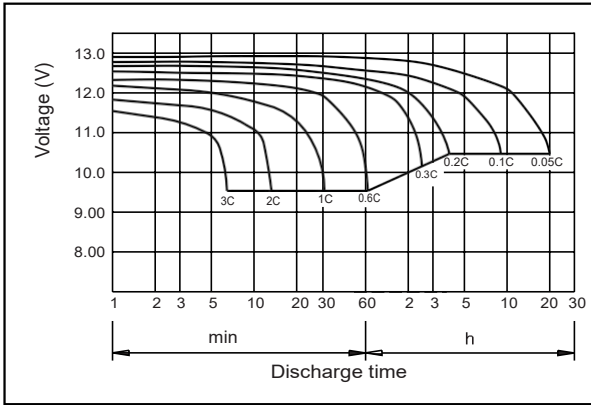

Temperature effects on Capacity

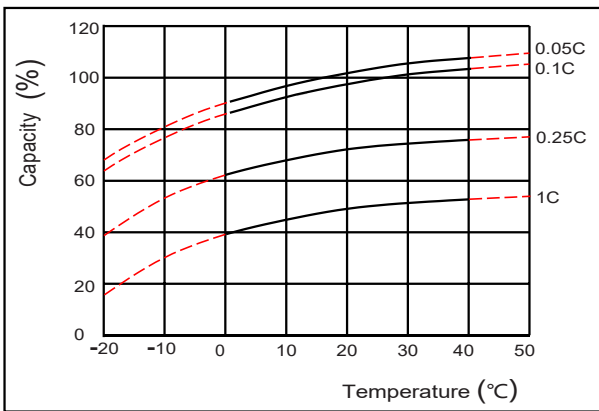

Floating life on Temperature

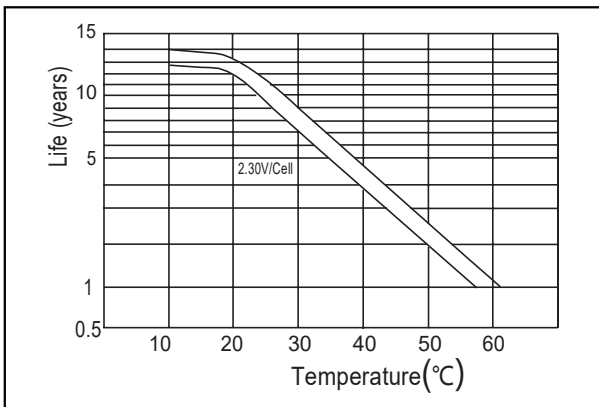

The relationship for OCV and Capacity (25°C)

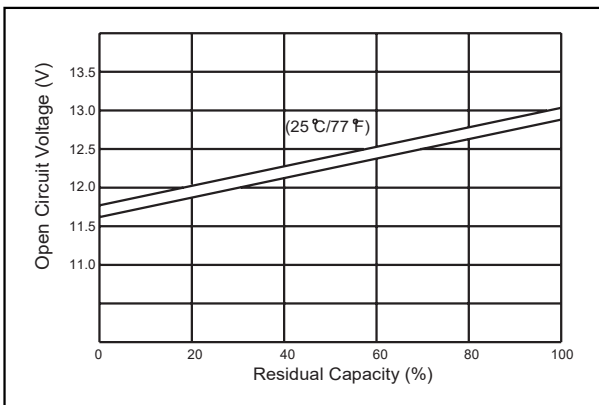

Charging characteristics (25°C)

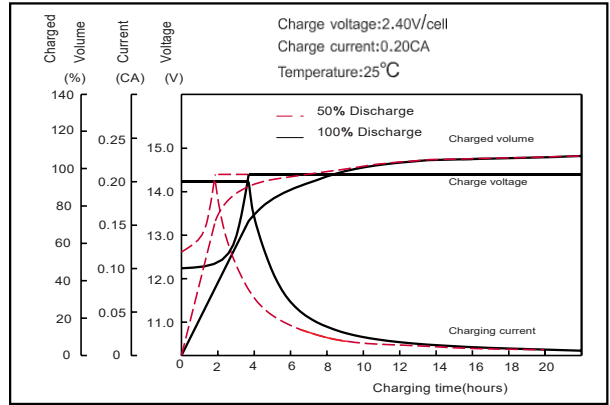

Self-discharge characteristics

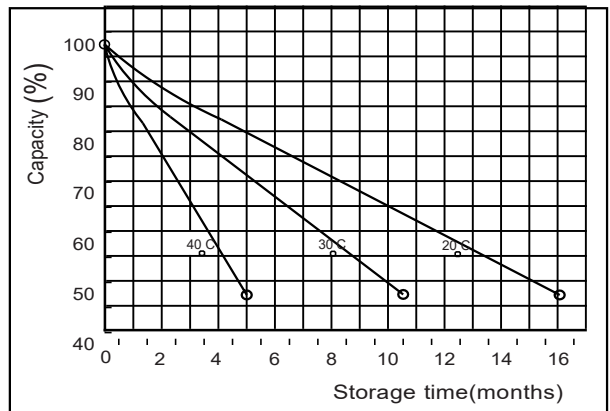

Cycle life on D.O.D (25°C)

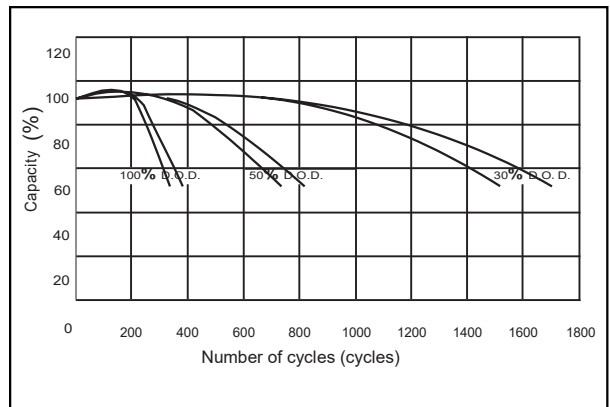

The relationship for Charging voltage and Temperature

